



ABV Sub-Sea Systems

ABV has developed a series of valves and actuators suitable for sub-sea service. The design of these systems comes from those for topside service with the implementation due to the external pressure presence and customer requirements in terms of reliability, operability and material corrosion.

ABV has dedicated a special division to the development of valves and actuators sub-sea since, even if the basis is the technology of the standard product, the problems and the technical solutions sometimes are completely different.

The possibility to design and manufacture both the actuator and the valve offers to **ABV** to realize personalized solutions, to modify easily the data of interface and to optimise the design.

Also from a manufacturing point of view there is a difference between standard production and production of sub-sea systems, since the controls of the materials, the cleanness of the assembly areas and the testing systems are completely different.

The manufacturing solutions adopted by **ABV** for the design and the manufacturing of sub-sea systems keeps into account primarily the requirements of the customer and of the technical specifications, that usually are different from design to design.

A general recommendation, valid for systems where a qualified life of 30 years and a high reliability are requested, is the following:

- Top entry or fully welded valves;
- Valves with metallic seal;
- Valves with forged body to avoid castings;
- Actuator body in nodular ductile cast iron;
- Actuator dynamic seal PTFE based to avoid stick-slip effect also after long period not operated and to have minimum friction;
- Cylinder in stainless steel material;
- Baric compensation;
- Cathodic protection for the whole system.

ABV has realized a study of reliability in cooperation with the University of Parma, with which it was evaluated a set of systems installed from several years of various manufactures and having different construction solutions.

The problems found with more frequency were highlighted and it was made an accurate study to determine the probability of failure, then the most critical points were individualized. The design of **ABV's** subsea system keeps into account the results of this analysis, foreseeing appropriate solutions for the various problems.

We have found that there were various needs, among with to realize particular redundant sealing, to use solutions that avoid the stick-slip phenomenon and to compensate the system to the pressure.

Design and dimensions may be subject to change without notice, except the dimensions established by international standard specifications.



ABV Sub-Sea Systems

The baric compensation is a factor extremely important for reasons of internal corrosion and guarantee of performances at all depths. The actuator and the spool are filled in with biodegradable oil and the equalization of the pressure between internal and external can be realized with different systems, which vary depending on the type of the actuator and the characteristics of the project.

In this way it is possible to design system with high reliability for depth up to 2500 meters and more.

ABV has qualified a valve 4" 1/16 API 3000 with the relevant actuator controlled by oil and by ROV in hyperbaric chamber simulating a depth of 2000 meters.

Lloyd's certification is available on request.

The reference for design is API 17D standard but special solution can be adopted to meet particular customer requirements.

Another point very important is the selection of materials, that is usually realized according to customer specifications with a special attention to problems of galvanic corrosion, compatibility of the contact fluids, the mechanical stress and the qualified life requested by the project, that can reach also 30 years.

So different materials can be used, carbon steel or ductile iron, S.S. 316 or duplex and superduplex.

Special attention is paid to the electric continuity to guarantee a good efficiency of the cathodic protection which is almost always requested for these systems.

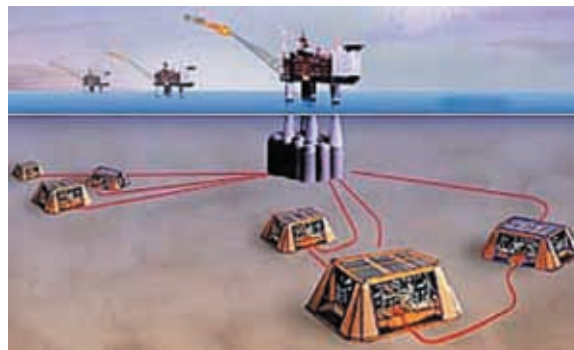

Design and dimensions may be subject to change without notice, except the dimensions established by international standard specifications.



ABV Series Sub-Sea Actuator

Sub-Sea Hydraulic Actuators SA-HDA

CHARACTERISTICS

- Hydraulic actuator.
- Double acting (single acting on request).
- Design life 30 years.
- Operable by R.O.V.
- Manual override on request.
- Mechanical/Tactile valve position indicator (remote on request).
- Separate flushing ports.
- Fully pressure equalization to assure complete internal corrosion protection, and to obtain the required performances at every operating depth.
- Possibility of installing the actuator on the valve by means of diver or R.O.V. assistance.
- Pressure containing parts according to ASME VIII.
- Power hydraulic oil cleanness according to NAS 6.



SUB-SEA SYSTEM

- Sub-sea Hydraulic Actuator.
- R.O.V. Interface.

ON REQUEST

- Quick Clutch-Declutch System.

Design and dimensions may be subject to change without notice, except the dimensions established by international standard specifications.



ABV Series Sub-Sea Actuator

Sub-Sea Hydraulic Actuators SA-HDA

DESCRIPTION

- A. Rov Mechanical Interface
API 17D type 4
- B. 2"/2500 Ball Valve Interface
- C. Hydraulic Connection 1/2 NPT

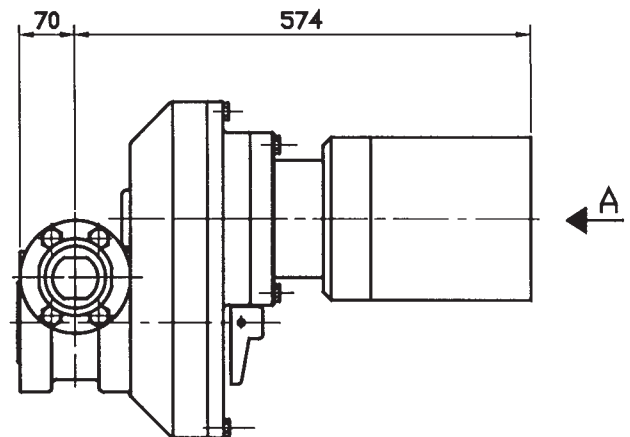
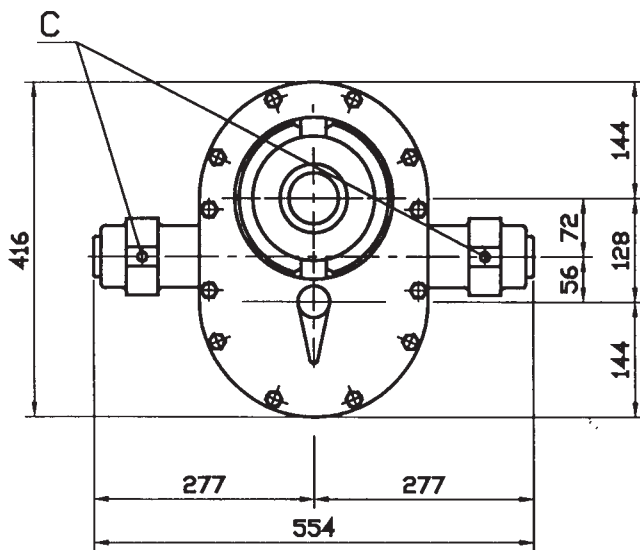
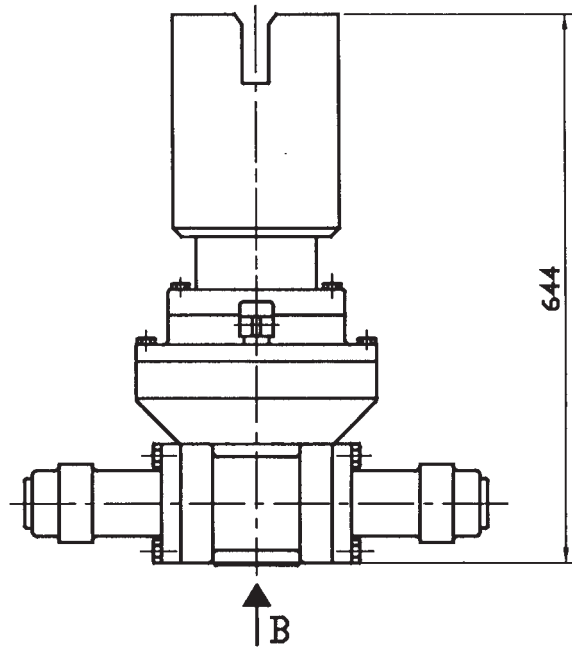

Design and dimensions may be subject to change without notice, except the dimensions established by international standard specifications.



ABV Series Sub-Sea Actuator

Sub-Sea Hydraulic Actuators SA-HDA

DESCRIPTION

1. Rov Interface
2. Seal
3. Rov Shaft
4. Screw
5. Flange
6. Bushing
7. Pin
8. Gear Housing
9. Bushing
10. O-Ring
11. Gear Shaft
12. Actuator Housing
13. Bushing
14. O-Ring
15. Pinion
16. Bushing
17. O-Ring
18. O-Ring
19. Screw
20. Gear
21. Bushing
22. O-Ring
23. Gear Cover
24. Position Indicator
25. Seal
26. Shaft
27. Cylinder Plug
28. Cylinder
29. Piston
30. Screw
31. O-Ring
32. Bushing
33. Rack
34. Sleeding Ring
35. Screw
36. Seal
37. O-Ring
38. Stopper

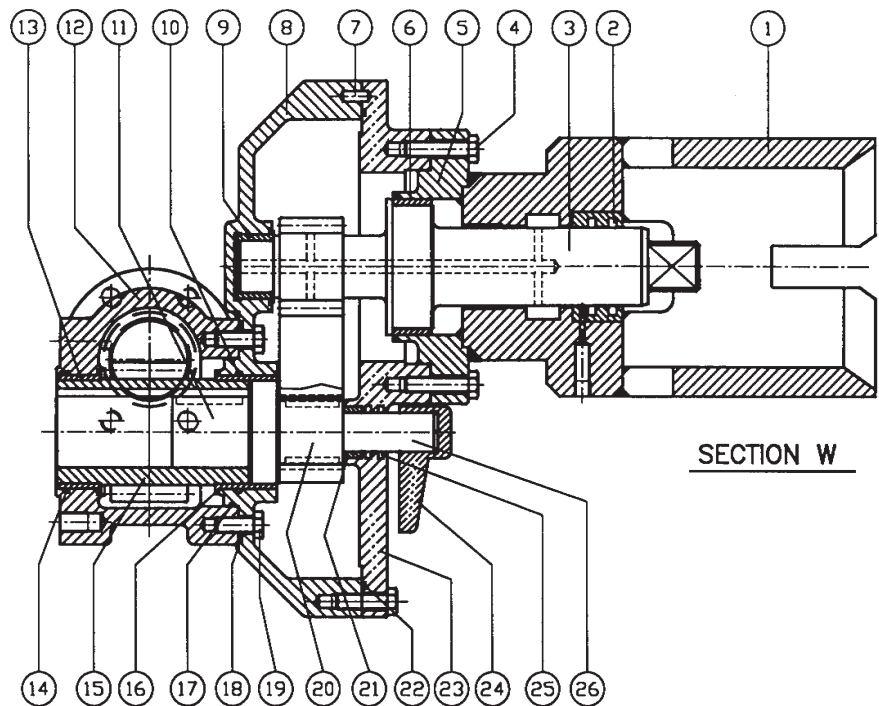
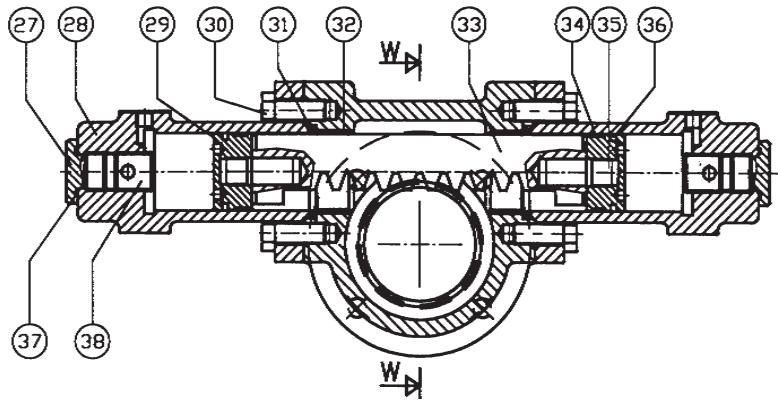

Design and dimensions may be subject to change without notice, except the dimensions established by international standard specifications.



ABV Typical Sub-Sea Actuators Mechanically Operated (Manual or by R.O.V.)

DESCRIPTION

1. Body
2. Coverplate
3. Quadrant
4. Position Indicator
5. Worm
6. Shaft
7. Set-screw
8. Seal
9. Bushing
10. Needle-Bearing
11. Protective Oil
12. Gasket
13. Gear
14. Seal
15. Gasket
16. O-Ring
17. O-Ring
18. Seal
19. O-Ring
20. O-Ring

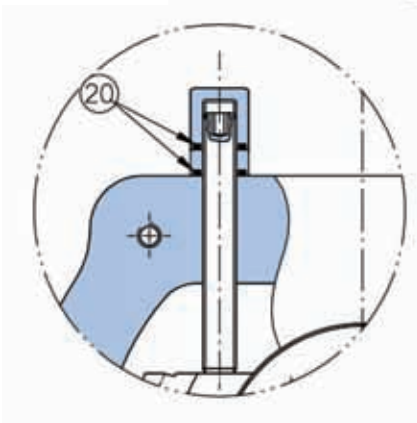
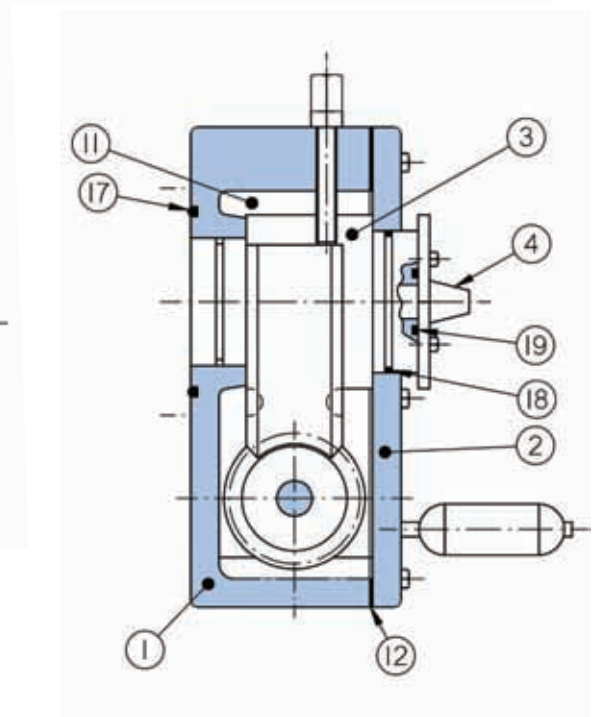
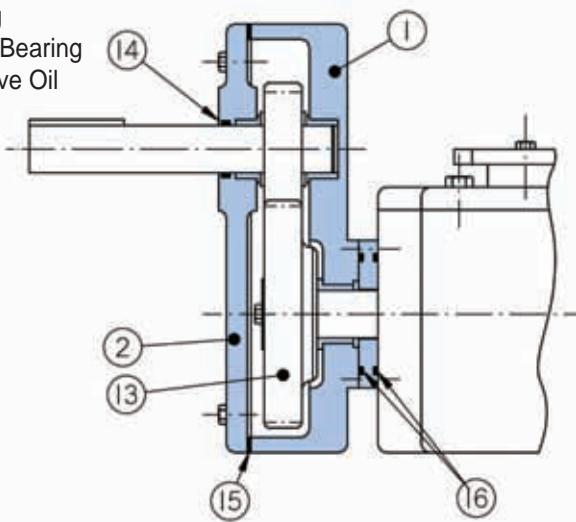
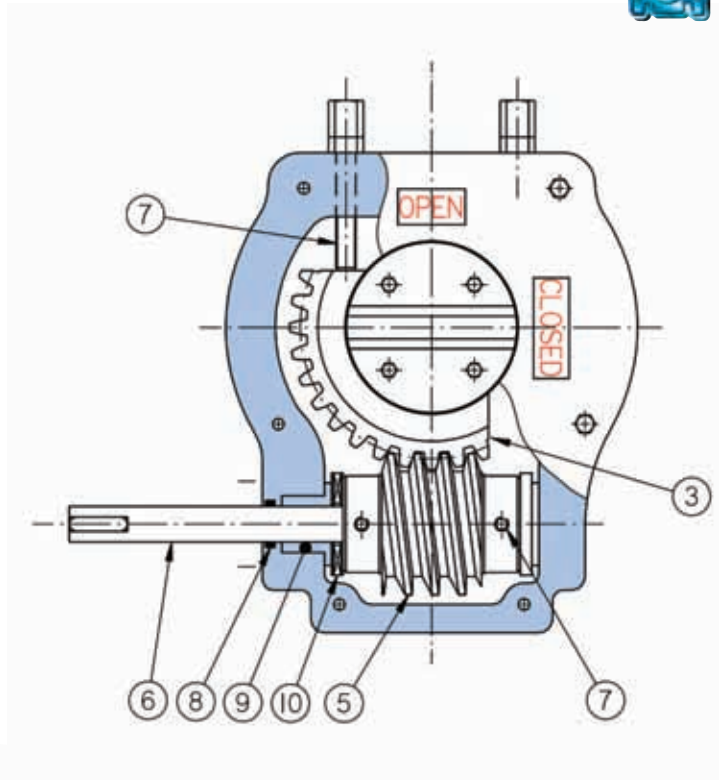

Design and dimensions may be subject to change without notice, except the dimensions established by international standard specifications.



ABV Operating Systems

R.O.V. Interface

All the **ABV S.r.l.** actuators can be designed to be operated also by R.O.V. (Remote Operated Vehicle).

The design is normally in accordance to API 17D STD, but **ABV S.r.l.** can design special interfaces according to customers requirements.

Hydraulic Devices

The **ABV S.r.l.** hydraulic actuators can be equipped with devices according to customer needs. These devices can be designed to be operated also without human attendance.

The most frequent customer requests are flushing valves and hydraulic control valves.

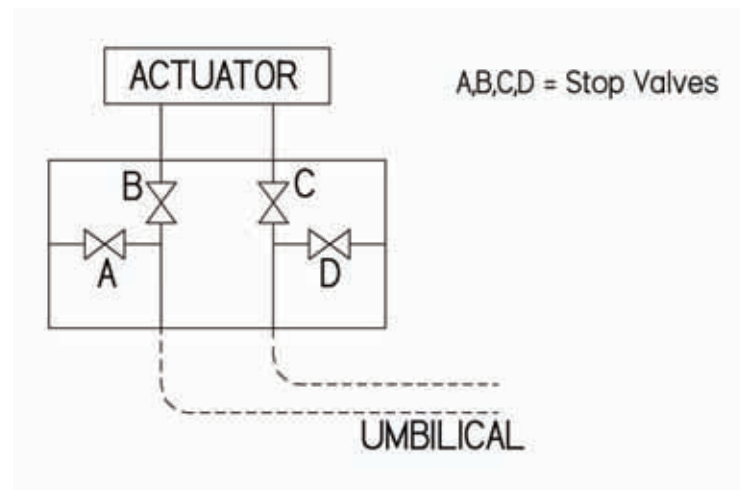

Typical control system (manifold type)
for umbilical flushing

Manual Override

On request, actuators can be provided with manual override, which can be mechanical (wheel) or hydraulic (pump).

The adopted solution and used materials are according to customer requirements.



ABV

Series TSB

Sub Sea Systems

Top Entry Sub-Sea Ball Valves

CHARACTERISTICS

- Top-Entry bolted bonnet design.
- Bi-directional valve.
- Trunnion mounted design, with floating seat rings and allowed cavity pressure relief in both open and closed position.
- Single piece floating seat ring.
- Body and stem non-metallic seals made in PTFE, PEEK or similar materials (not in elastomeric materials).
- Inconel 625 overlay on seats and seals area (on carbon steel valves).
- Electrical continuity between stem, ball and body.
- Piggable.

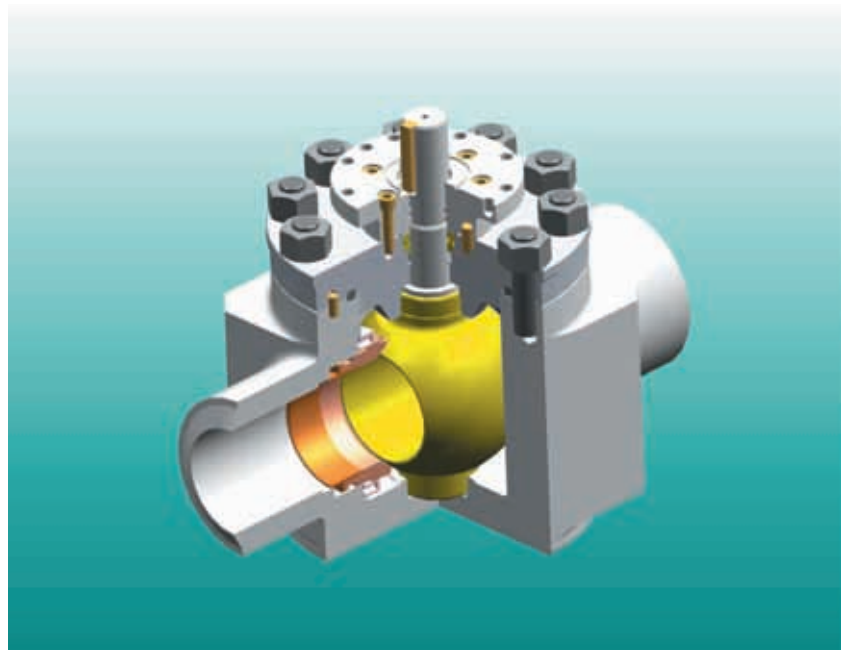

AVAILABLE SIZES & RATING

• NS 1/2" ÷ 24"	ASME 150 ÷ 2500#	Full and reduced bore
• NS 1/2" ÷ 16"	ASME 2500	Full and reduced bore
• NS 1/2" ÷ 8"	ASME 4500	Full and reduced bore
• NS 1" ÷ 4.1/16"	API 2000 ÷ 15000	Full and reduced bore

Design and dimensions may be subject to change without notice, except the dimensions established by international standard specifications.



ABV Series TSB Sub Sea Systems

Top Entry Sub-Sea Ball Valves

DESCRIPTION

1. Body
2. Bonnet
3. Adapter Flange
4. Seat
5. Ball
6. Stem
7. Spring
8. Bearing
9. Cap Screw
10. Nut
11. Stud Bolt
12. Vent Plug
13. Spring
14. Thrust Washer
15. Thrust Washer
16. Stem Key
17. Lip Seal
18. Ring Joint
19. Drain Plug
20. Pin
21. Lifting lug
22. Threaded Ring
23. Stem Gasket
24. Lantern Ring
25. Bearing
26. Welded Pin
27. Bearing
28. Seat Gasket Ret.
29. O-Ring
30. O-Ring

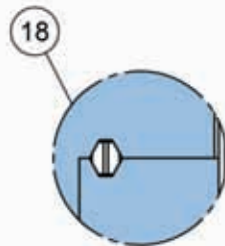
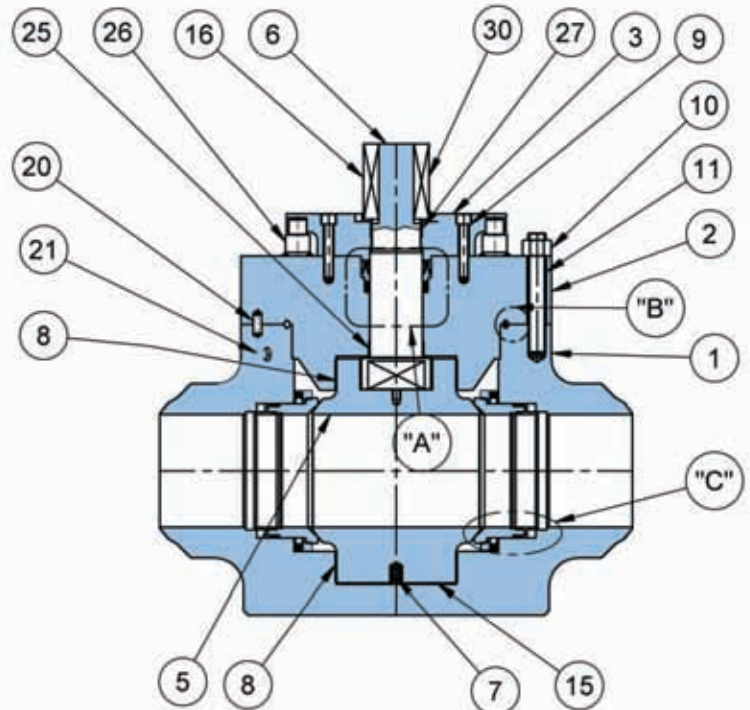

DETAIL "B"

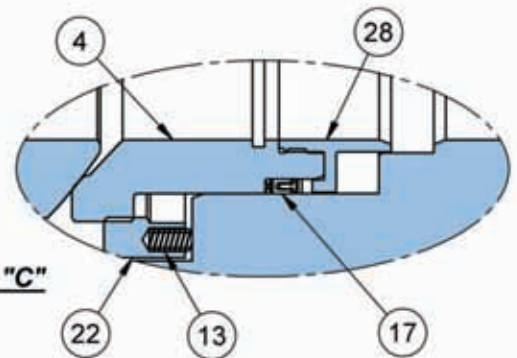

DETAIL "C"

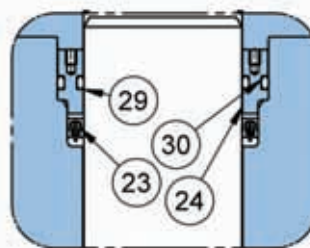

DETAIL "A"

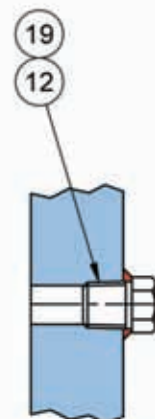

DRAIN & VENT PLUG

Design and dimensions may be subject to change without notice, except the dimensions established by international standard specifications.



ABV

Series WSB

Sub Sea Service

Fully Welded Sub-Sea Ball Valves

CHARACTERISTICS

- Fully welded design.
- Bi-directional valve.
- Trunnion mounted design, with floating rings and allowed cavity pressure relief in both open and closed position.
- Single piece floating seat ring.
- Body and stem non-metallic seals made in PTFE, PEEK or similar materials (not in elastomeric materials).
- Inconel 625 overlay on seats and seals area (on carbon steel valves).
- Electrical continuity between stem, ball and body.
- Welding according to API 6A PSL3 and ASME IX.
- Piggable.

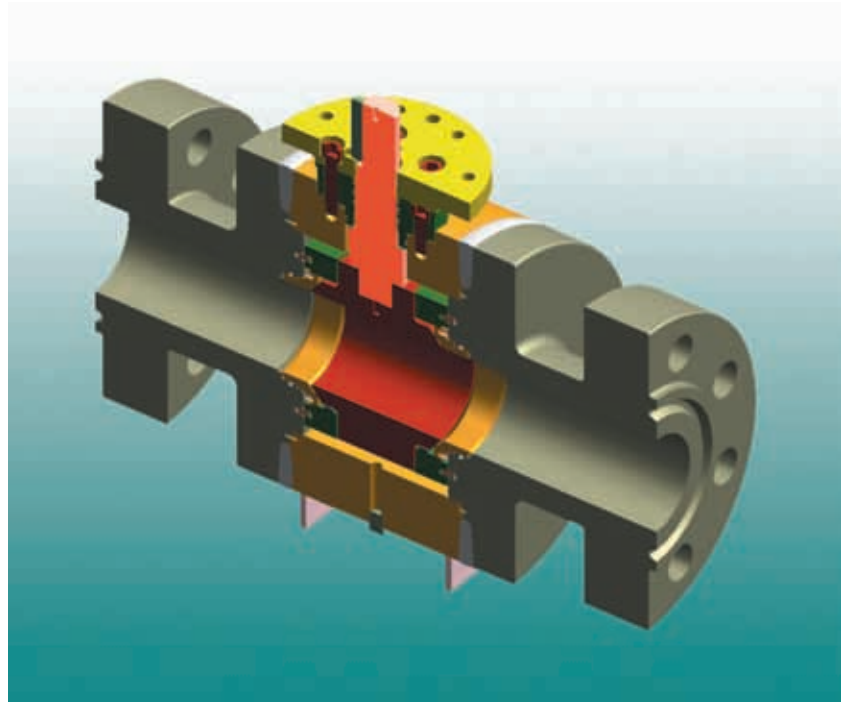

AVAILABLE SIZES & RATING

• NS 6" ÷ 40"	ASME 150 ÷ 600#	Full and reduced bore
• NS 6" ÷ 36"	ASME 900#	Full and reduced bore
• NS 6" ÷ 30"	ASME 1500#	Full and reduced bore
• NS 6" ÷ 24"	ASME 2500#	Full and reduced bore
• NS 6" ÷ 8"	ASME 4500#	Full and reduced bore
• NS 4.1/16" ÷ 7.1/16"	API 10000	Full and reduced bore
• NS 4.1/16"	API 15000	Full and reduced bore

Design and dimensions may be subject to change without notice, except the dimensions established by international standard specifications.



ABV

Series WSB

Sub Sea Service

Fully Welded
Sub-Sea Ball Valves

DESCRIPTION

1. Body
2. Bonnet
3. Adapter Flange
4. Seat
5. Ball
6. Stem
7. Spring
8. Bearing
9. Cap Screw
10. Nut
11. Stud Bolt
12. Vent Plug
13. Spring
14. Thrust Washer
15. Thrust Washer
16. Stem Key
17. Lip Seal
18. Ring Joint
19. Drain Plug
20. Pin
21. Lifting lug
22. Threaded Ring
23. Stem Gasket
24. Lantern Ring
25. Bearing
26. Welded Pin
27. Bearing
28. Seat Gasket Ret.
29. O-Ring
30. O-Ring

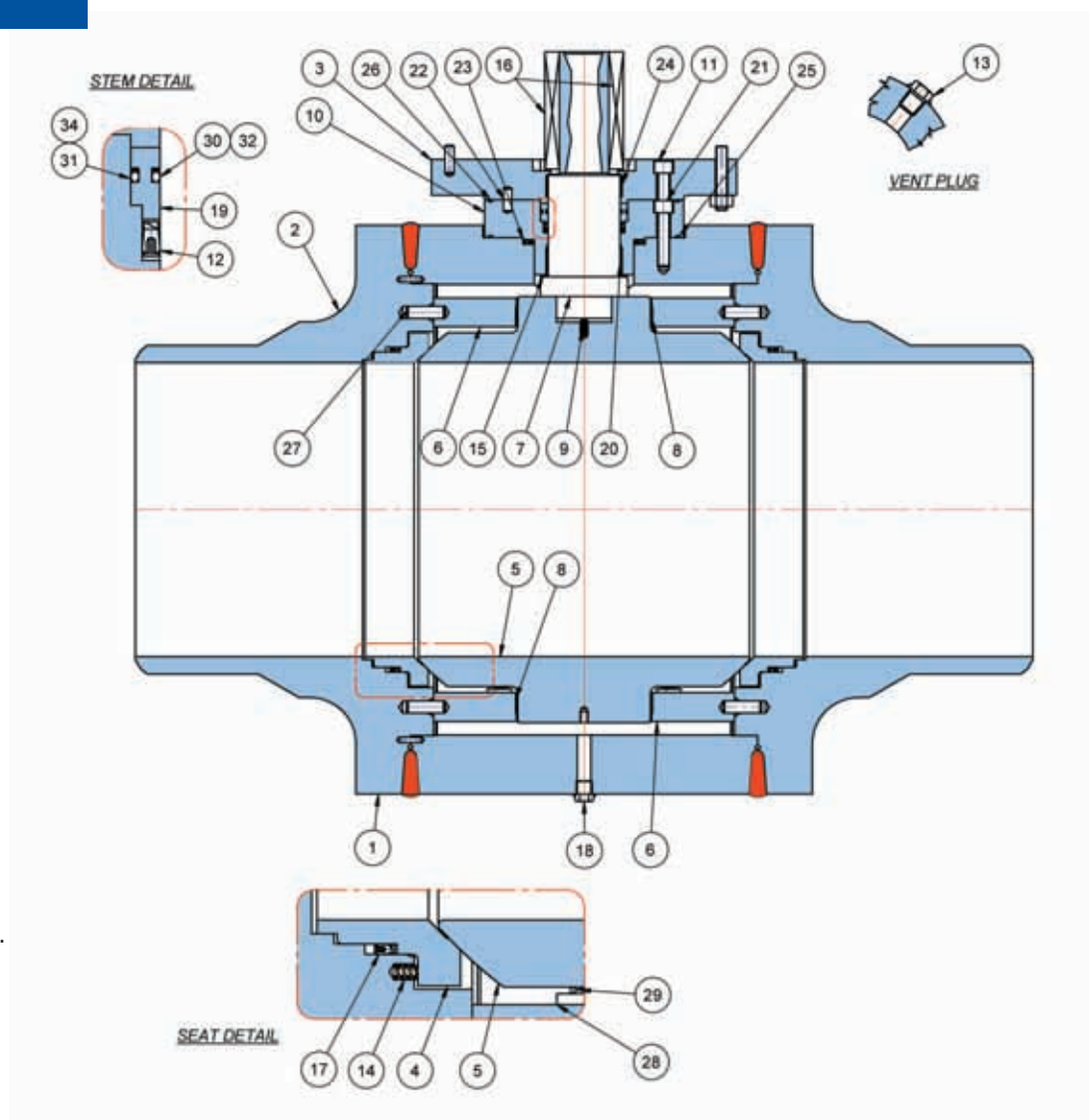

Design and dimensions may be subject to change without notice, except the dimensions established by international standard specifications.



ABV Sub- Sea Actuator Moss® Integral System

CHARACTERISTICS

- Sub-sea system based on ball valve with integrated actuating mechanism.
- System without exposed or moving external parts.
- System with low pieces number, high reliability and maintenance free.
- Easy cylinder assembling and disassembling, and diverless possibility.
- Flexibility and reducing of overall dimensions.
- Possibility to operate by pneumatic, hydraulic (single or double acting), ROV or manual.
- Possibility to have total metallic seats (zero leakage), and constant valve pressure also after cylinder removing.

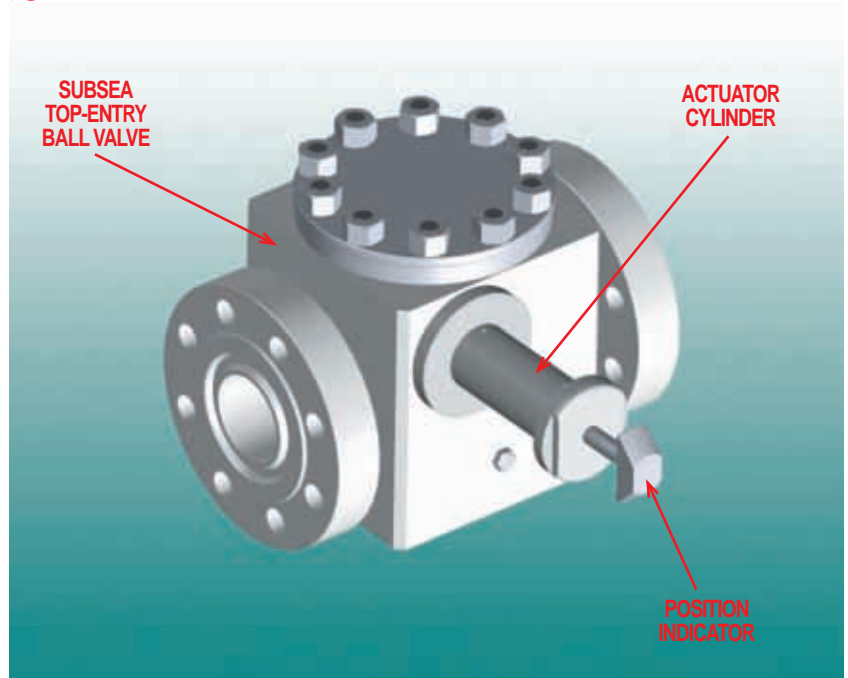

Moss® typical configurations

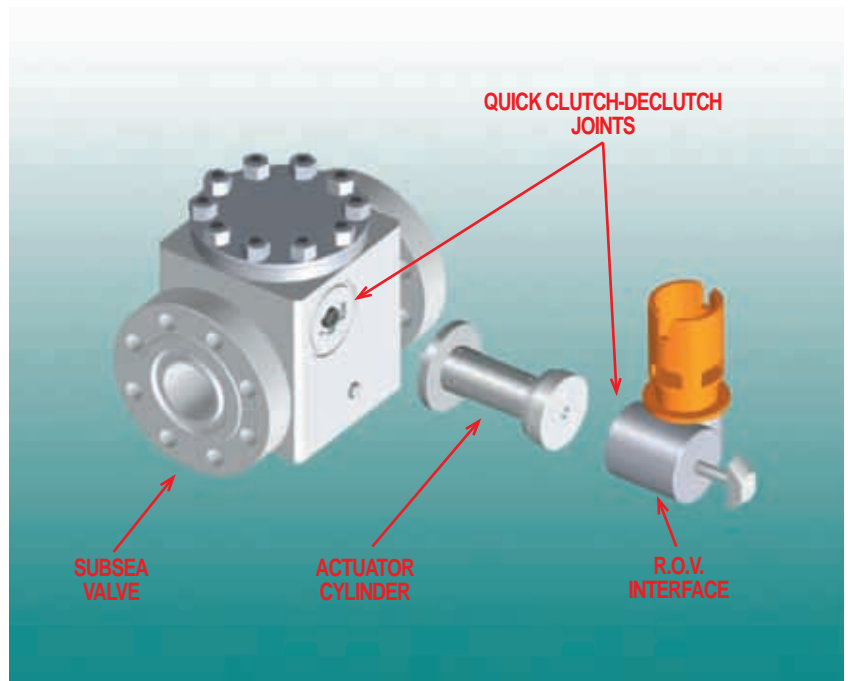

Moss® Integral System is patented by ABV S.r.l.
Moss® is a registered trademark of ABV S.r.l.

Design and dimensions may be subject to change without notice, except the dimensions established by international standard specifications.